

Sewer Overflow Tracking and Alarm System

Avoid spills and high level conditions with early notifications

Track Manhole Surcharges and Overflows

Floats tipped by surcharges and high levels signal Mission servers to initiate notifications via phone, email, text message, fax and pager. Secure web portals display the time and duration of the events.

Simple to Install and Maintain

The Manhole Monitor is battery operated with quick connecting antenna and float terminations for fast and easy installation. The cellular device installs in the chimney of the manhole using a versatile mounting bracket. The bracket allows the waterproof device to swivel upward during maintenance for convenient viewing. The unique in-road antenna installs adjacent to the manhole. Installation can be completed with common tools and does not require manhole cover modifications or entry into the manhole.

Waterproof, Self-Contained and Safe in Sewers

The completely redesigned, all metal enclosure is robust and serviceable. It features a replaceable battery and isolated termination and electronic cavities. The device is built to meet requirements for use in Class 1, Division 2, Groups C and D hazardous environments. It is designed and tested to IP68 specifications for submersion up to depths of ten feet for four hours.

User Friendly

Startup is simple with a sixteen character LCD that validates proper operation and displays optional advanced configuration settings. The user accessible pushbutton switch allows navigation through the display. Alternate languages can be selected.

Reliable Communications

The advanced Manhole Monitor features fourth generation (4G) radios for reliable data transmissions. The device features fully acknowledged data payloads - unlike SMS messages. There are no radios to program, cellular contracts to set up or software programs to buy.

Managed Service – The Complete Package

The service includes all communications, data storage, alarm call outs, reports and technical support. Alarm conditions are recorded and reported in real time while device health status is transmitted daily. All data and reports can be accessed from any web-enabled device. No engineering or programming is required.

Long Operating Life

The ultra-efficient circuitry draws minimal power from the field replaceable battery. This makes the low-power device capable of routine daily transmissions for over five years.



- **Receive Alarms and Data on Surcharges and Overflows**
- **Fully Managed Service Includes Communications, Alarm Call Outs and Web Portals**
- **4G Radio for Reliable Data Transmission**
- **Rugged, All-Metal, Waterproof Enclosure**
- **LCD Simplifies Startup and Optional Advanced Settings**
- **High Capacity, 5 Year, Field Replaceable Battery**

Dimensions

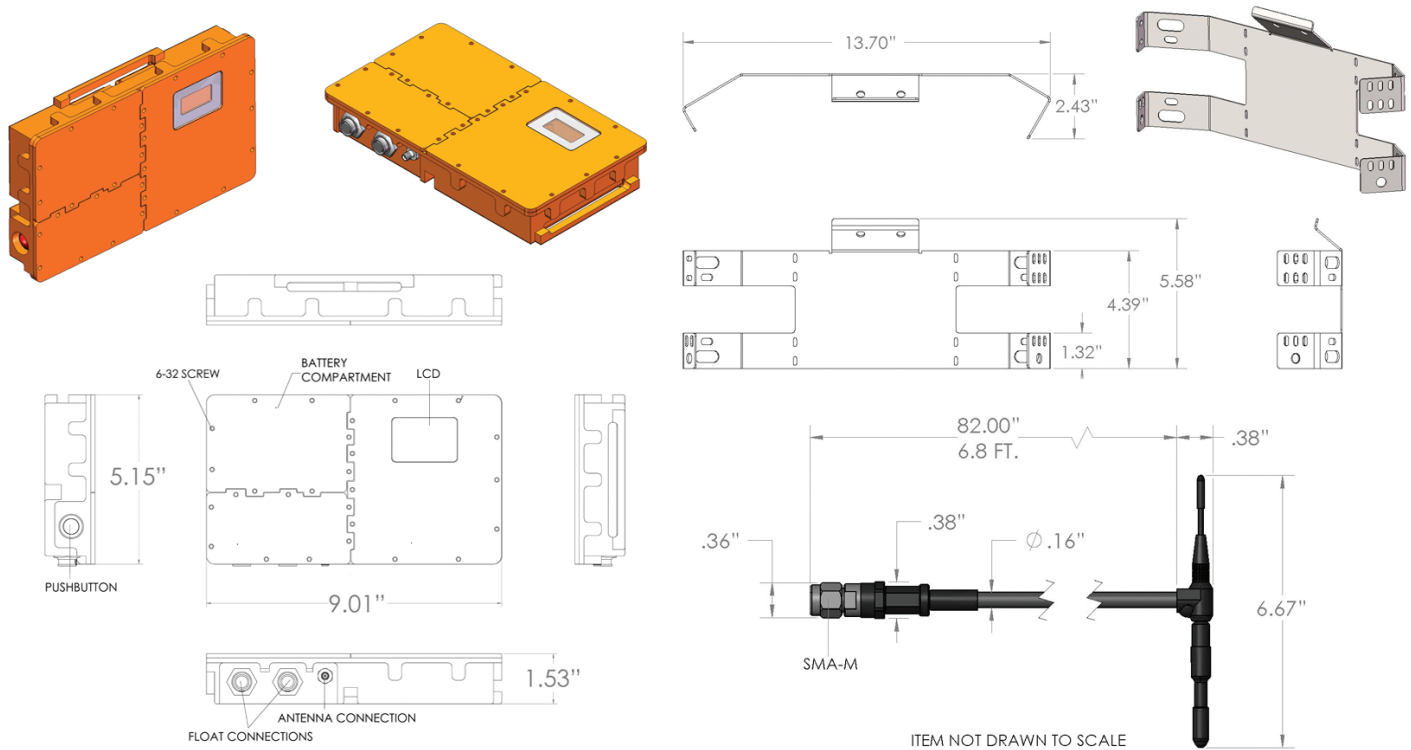

Specifications

Enclosure:

- Solid aluminum enclosure with serviceable compartments
- Double coated for corrosion resistance
- Polycarbonate display lens

Power:

- Replaceable 6.0 VDC lithium manganese dioxide battery
- 36.6 watt-hour capacity
- 5 year nominal lifetime

Float Inputs:

- (2) dry contact inputs
- Alarms on state change
- Configurable debounce delay for nuisance alarm prevention
- (2) Mercury-free floats; 2 wire, 20' water resistant, safety colored cable, normally-closed, mechanically-activated, 90 degree open
- Floats terminated with molded SwitchCraft EN3 harsh environment connector with integral O-Ring and locking bayonet

Radio:

- 4G cellular modem
- Five-band UMTS/HSPA+ (800/850/AWS1700/1900/2100 MHz) and quad-band GSM/GPRS, EDGE (850/900/1800/1900 MHz)

Antenna:

- In-ground, omnidirectional (PN R8001)
- Water-tight SMA male (cable) to SMA female (enclosure) connection

Installation Hardware:

- Stainless steel, multifaceted mounting bracket
- (4) TapCon stainless steel masonry bolts, 1/4" x 2 1/4"
- (2) Carabiners
- Tie wraps
- Asphalt sealant
- Drying agent
- (1) 3/16" diameter masonry drill bit

Physical:

- Enclosure: 5.15" W x 1.53" H x 9.01" L"
- Enclosure: 3.6 lbs.
- CAD files available for enclosure and mounting bracket

Configuration and Diagnostics:

- Liquid crystal display (LCD)
- Pushbutton switch
- Device information
- Optional configuration parameters
- Language selection (English, Spanish and French)

Environment:

- Operating: -10 to 50 deg C
- LCD: 0 to 60 deg C
- Pending certification for Class 2, Div 2 Groups C and D hazardous environments
- Meets IP68 requirements; waterproof up to depths of 10' for four hours and 4' for twenty four hours
- EU RoHS compliant

Warranty:

- Enclosure and electronics: 5 years
- Battery: 5 years based on 500 transmissions per year*
- Floats: 1 year

*Additional service plans available for higher data transmission rates.

Optional Accessories:

- Above ground antenna post (PN 446)
- Replacement in-ground antenna (PN R8003)
- Pole mount antenna kit (PN R8005)
- Replacement battery (PN P8202)
- 10' Float (PN I8503); 20' Float (PN I8502); 30' Float (PN I8504)
- Masonry drill bit, 3/8" x 24" (PN T9000)
- EN3 solderable terminal kit (PN A8401)



(877) 993-1911 • sales@123mc.com • www.123mc.com

©2013 Mission Communications. The Mission Communications logo is property of Mission Communications. All Rights Reserved. Protected under patents 7,216, 145. Specifications subject to change without notice.