

Welcome,

This manual is intended to guide end-users through the proper installation for MyDro (M150 and M850) remote terminal units (RTUs). The beginning chapters focus on pre-installation and are intended to optimize installation. Mission recommends that users read this document completely and confirm that all necessary materials have been gathered before beginning the installation process.

Prior to installation, users should complete and submit the RTU Setup Forms associated with the units to be installed to setupforms@123mc.com. New customers will have additionally received the Account Setup Form and Notification Setup Form, which should also be submitted before installing RTUs.

See the back cover of this document for information about available support resources, including weekly webinars, training tutorials, and troubleshooting documentation.

Mission Technical Support is available 24-7-365 on a responsive callback basis for after-hour emergencies at (877) 993-1911 option 2 or techsupport@123mc.com. Please have the customer name and appropriate unit serial number ready.

Thank you,
The Mission Communications Team



Warning: This symbol indicates there is caution or warning to avoid damage to your property or product.



Note: This symbol indicates that there is something that requires your special attention.



This device complies with part 15 of the FCC Rules. Operation is subject to the following two conditions: (1) This device may not cause harmful interference, and (2) this device must accept any interference received, including interference that may cause undesired operation.



This device is SGS Safety Certified

710198

Contents

Chapter 1: Overview	4
Chapter 2: Site Survey and Connectivity Test	6
Chapter 3: Antenna Installation	8
Chapter 4: RTU Installation and Wiring	10
Chapter 5: RTU Startup	16
Chapter 6: Test the Installation	17
Chapter 7: Electronic Key	20
Chapter 8: Site Commissioning	22
Appendix A: Terminology	23
Appendix B: Solid State Relay Wiring Diagram	25

Chapter 1: Overview

M150/M850 at a Glance

Each RTU is packaged with everything necessary for a standard installation

Enclosures

NEMA 1—indoor mounting

NEMA 4X—outdoor mounting

FlatPak—control panel inner door mounting

FlatPak Retrofit—(convert M110 or M800 to MyDro)



Hardware Included with RTUs

- RTU with NEMA 1, NEMA 4X, or FlatPak enclosure
- RTU Installation Packet: RTU Form, User Guide, and emergency notice label
- Battery—12 volt, 5 Amp-hour
- Flying Lead Transformer—120 VAC to 12 VAC, 1.2 Amp
- Universal Antenna Mount Kit: 11' RG58 cable with SMA-M connector, pole, or wall mount bracket, mini whip antenna, (2) pole clamps, and (2) MOVs rated for 120-volt control circuits
- Accessory Bag: (4) 1000 ohm long, yellow EOL resistors, (8) 1000 ohm EOL resistors, (2) current sensing switches, tie wraps, (4) wire nuts, (8) screws, (2) ferrite cores, and an interchangeable Phillips/flathead screwdriver

New customers will also be given a New Customer Packet which includes Account and Notification Setup Forms, (5) electronic keys with instructions, and the Managed SCADA document.



Recommended Tools and Materials (Not Included)

Mechanical Tools	Electrical Tools	Materials
Drill motor	Voltmeter/multimeter	18 or 22 gauge wire—2, 4, or 8 conductor stranded and shielded
Step drill or 3/4" hole saw	Wire cutters	12–14 gauge green wire for grounding the RTU (follow NEC standards)
Hack/reciprocating saw	Wire strippers	3/4" Flex conduit with straight and elbow fittings
Metal cutting blades		Unistrut rail and hardware for mounting
Pliers		Interposing relays and bases (if no dry contacts are available)
5/16" nut driver		Interposing relay (if output relays will be used)
Phillips-head screwdriver		Sealant
Ladder (for antenna mounting)		

Available Input/Output Expansion

Mission offers a variety of expansion modules to extend the utility of the RTU. Available options are summarized below:

- Safe Module Plus: intrinsically safe float circuit, local relay, 4 pulse channels
- Digital Input: adds 8 channels
- Digital Relay Output: adds 6 digital relay output channels
- Analog Input: adds 7 channels
- Analog Output: provides 4 channels



For more information, see the Safe Module Plus and MyDro Expansion Module specification sheets, as well as the Expansion Module Installation manual.

Chapter 2: Site Survey and Connectivity Test

Prior to installation, please complete and submit the RTU Installation Form via email to setupforms@123mc.com so Mission can set up the new unit(s) on your web portal. New customers must also complete and submit both forms within the New Customer Packet. The web portal can be accessed with the login credentials you provided within the Account Setup Form. Once completed and entered by Technical Support, alarms can be enabled for your RTU(s) immediately after installation so you can perform end-to-end testing.

By powering the RTU and testing connectivity before mounting the hardware, you can optimize the signal strength for years of trouble-free communication. The test only takes a few minutes, and the included battery provides temporary power. Refer to Chapter 3 for best practices when positioning the antenna.

1. Remove the RTU from the box and place it on or near the control panel it will be monitoring. Remove the antenna cable and antenna whip from the package and hand-tighten the SMA-M connector to the radio SMA-F connection on the RTU (see Figure 1).
2. Screw the antenna whip onto the molded antenna base and place it outside as high as possible. Mount the antenna to the aluminum bracket.



Warning: Hand-tighten the nut on the underside plus 1/4 turn with a wrench. Do not overtighten.

3. Power the RTU with the 12 VDC battery (see Figure 1). Connect the negative (black) lead to the battery and then connect the positive (red) lead. Once the startup sequence is completed, you will hear three beeps from the buzzer. This indicates the unit has connected to Mission servers. If the RTU does not connect after two attempts, call Technical Support.
4. Notice the signal strength (RSRP) reading on the LCD as shown in Figure 1. The goal is to mount the antenna where the signal is the strongest. A -75 dB signal is better than that of -100 dB. A signal quality (RSRQ) reading closer to 0 is better. Temporarily position the antenna for about a minute in a few locations and take note of the signal strength.
5. When this test is complete, disconnect the battery.

Figure 1:
Main Printed Circuit Board Wired for Site Survey

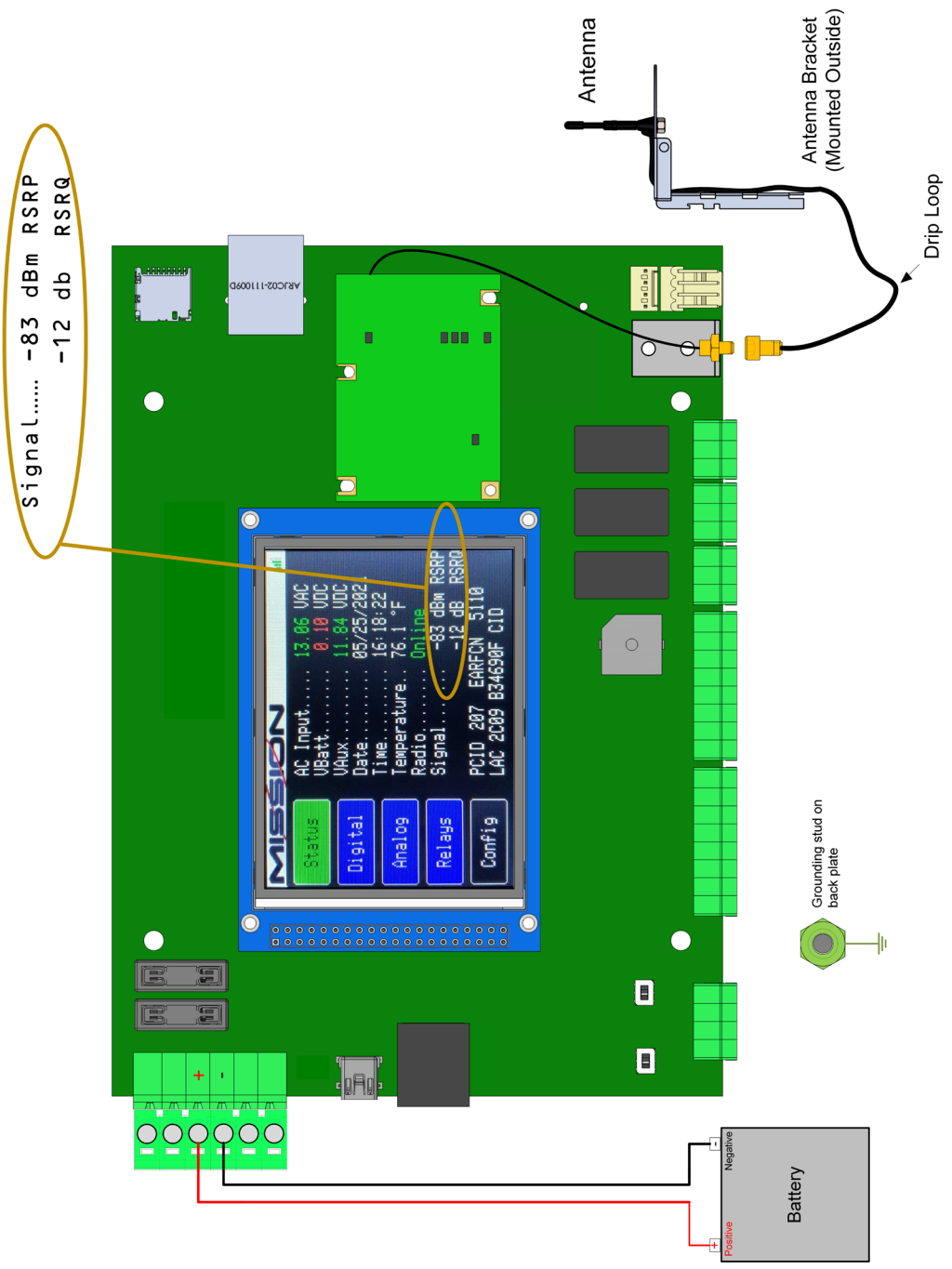

Chapter 3: Antenna Installation

Overview

The antenna should be mounted outdoors and above other objects. By optimizing the placement of the antenna, you increase the chances that the radio can communicate with more than one cell tower. The coaxial cable should reach the Mission RTU radio connection with no severe routing of the coaxial cable. Consider where the RTU will be mounted in relation to the location of the antenna.

1. Install the antenna cable and antenna whip. Connect the SMA-M cable connector to the SMA-F connector on the mainboard (see Figure 1). Unscrew the nut from the molded antenna base. Feed the molded antenna base through the square cut out on the bracket. Place the molded antenna base in the circle cutout.



Warning: Secure the molded antenna base to the bracket with the nut. Hand-tighten the nut, plus $\frac{1}{4}$ turn with a wrench. Do not overtighten.

2. Install the mounting bracket. Mount the Universal Antenna Mount directly on the face of a flat surface or a metal pipe using the included pipe clamps (placing above any obstruction).



Hose clamp nut

Tie wrap

Antenna Best Practices

Do	Don't
Mount the antenna outside as high as possible, preferably above the roof or other objects.	Mount the antenna underground, in a dry well, or inside a canned lift station.
Mount the antenna above all metal surfaces close to the installation.	Mount the antenna horizontally or bend the antenna whip.
Coil excess coaxial in circles of 5–7 inches in diameter. Pinching or tight bends in the coaxial can restrict the high frequency/low power radio signal path in much the same way water flow is restricted through a tight bend in a hose.	Mount the antenna inside a metal control cabinet. Even fiberglass cabinets degrade the signal.
Ensure that the weight of the cable does not damage the antenna base. There should be enough slack in the cable so it does not rest or touch the top surface of the mounting bracket.	Mount the antenna on the side of a metal cabinet or adjacent to a tank. Metal surfaces will reflect the radio signal, preventing it from traveling in all directions.
Incorporate a drip loop when installing the cable to prevent water from penetrating into the building or enclosure.	Cut, lengthen, or shorten the coaxial cable. Mission can supply antenna extension cables and connectors up to 50 feet. For lengths above this limit, another RTU mounting location should be considered.

Wiring Best Practices

- Signal cables should not run parallel with high voltage AC wires (load conductors).
- Where signal wires and load conductors must cross, do so at right angles.
- High voltage should not enter the Mission RTU. Mount the supplied transformer outside the Mission enclosure.
- Lay wires in wire trays with the excess near terminations. Replace wire race covers
- Cables used for digital and analog inputs should be 18 to 22 gauge, shielded, twisted pair wire with the shield connected to ground at the RTU and not on the other end of the cable (to prevent ground loop current).
- MOVs can be installed across AC contactor coil terminals to shunt voltage spikes away from the RTU inputs and other electronics in the panel. Voltage spikes can be caused by coils de-energizing. The included MOVs are rated for 120 V circuits and will suppress excess voltage above 150 V. These parts are application dependent. They have a finite lifespan and will need to be replaced over time.



Warning: Follow requirements for field wiring installation and grounding as described in NEC and the local/state electrical codes.

Chapter 4: RTU Installation and Wiring

Locate the RTU as close as possible to the control cabinet while considering the antenna cable length.



Warning: Turn off station power to avoid damage to mainboard.



Note: MyDro units should be connected to an LPS-certified power supply (12 VAC 60 Hz ~ or 17-22 VDC).

1. Mount the enclosure.
2. Cut the conduit and wiring holes. Drill and attach the conduit in the control cabinet and Mission RTU. Use sealant where appropriate.
3. Pull the wires and cables.
4. Ground the RTU. Use 12 to 14 gauge green wire to connect the grounding lug on the backplate in the RTU to the stations Earth ground (refer to Figure 1).
5. If using the Safe Module Plus for sensing the high-level float in an intrinsically safe manner, install it now. Refer to the MyDro Expansion Module Installation Manual for more information.

Keep in mind that DI4 will be used by the SMP and not available on the MyDro itself. See Figure 6: Emergency Backup Pump Control wiring. Complete the remainder.
6. If configuring this MyDro with the Emergency Backup Pump Control feature, install the second SMP (set as low float) at this time.
7. Terminate digital inputs. Refer to the wiring diagram on the M150/M850 cover/door and the RTU Installation Form in the packing box. Record input names on the setup form and the diagram.

Enclosure Options

NEMA 4X

Mount outdoors on unistrut or a wall. Allow clearance for hinge (left) and key reader (right).

Consider the NEMA 4 for indoor application where wash-downs occur.

Conduit connections can enter from bottom, but leave space for the included battery.



NEMA 1

Use indoors where no wash-downs occur.

Allow for space on bottom of the enclosure for the battery.

FlatPak

Mount inside the control cabinet.

Two large holes are provided for through-wires.

Place battery inside the control cabinet.



Important: Although it is workable to connect non-intrinsically safe floats to the digital inputs, it is strongly recommended that floats are connected through the intrinsically safe SMP (OP750).

The default digital input (DX) connections are as follows:

- D1—pump 1 (M150 runtime accumulator, M850 status and runtime accumulator)
- D2—pump 2 (M150 runtime accumulator, M850 status and runtime accumulator)
- D3—pump 3 runtime or simultaneous pump (1 and 2) runtime accumulator*(M150)
- D4—high level float (and EBPC start when using EBPC feature)
- D5—pump 1 fail
- D6—pump 2 fail
- D7—phase fail
- D8—unassigned, multiple pump runtime accumulator*(M850), or low level float (EBPC)

MyDro Digital Inputs feature software selectable input characteristics including:

- Dry contacts with wire fault supervision (requires 1000 ohm EOL resistors)
- Dry contacts no wire fault supervision (NF)
- Strap on current sensing switches (Mission PN OP400) with wire fault supervision
- Strap on current sensing switches (Mission PN OP400) without wire fault supervision



Note: The MyDro does not directly support the Wet Well Module. See the technical document, Wet Well Module with MyDro, if updating M110 or M800 with Wet Well Module to a MyDro.



Warning: MyDro digital inputs require dry contacts. This means that wires running to these inputs must not supply any voltage. Use an interposing relay if there are no dry contacts available.

The digital inputs are set as normally open (N/O) by default. You must use N/O contacts on pump runtime inputs. You may use either N/O or normally closed N/C contacts on digital inputs 4 through 8. Notify Mission Technical Support (or indicate on RTU setup form) to change the default settings (refer to Figure 2). Connect the shields of digital input wires to the grounding lug located inside the RTU.

Pump Runtime Inputs: On M150 RTUs, only inputs D1–D3 can be configured for pump runtimes. However, they can also be set as alarm inputs. D4–D8 on an M150 can only be configured as alarm inputs. D3* can be used for simultaneous runtimes by configuring digital input on touch screen.

On M850 RTUs, D1–D8 (on the main board) can be configured as pump runtime, pump runtime with alarm, or alarm inputs. As an option, the system can report multiple pump runtimes on M850 RTUs on **D8.***

Wire fault supervision: EOL resistors are optional with the MyDro. When utilized and installed properly (at the far end of the cable wired parallel to the switch) they allow the system to alarm on a wire fault. Software selection of this is done from the touch screen. From the config screen, go to Digital Input Setup and then Mode. Choose Digital Input Dry Contact NF for no EOL resistor (no wire supervision).

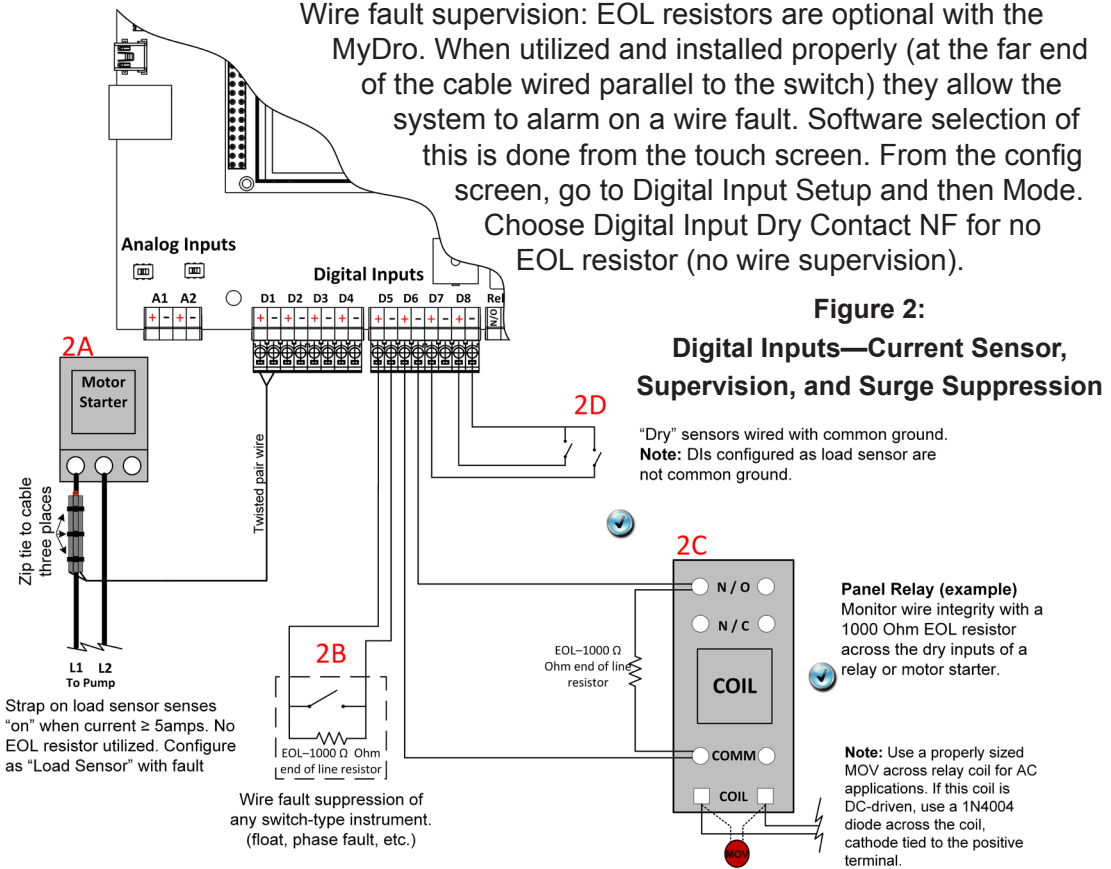

8. Terminate analog inputs. Two isolated analog inputs are available on the mainboard (refer to Figure 3). These inputs can accept a 4–20 mA or 0–5 volt signal. Position analog channel signal selector* to the left for a 4–20 mA signal and to the right for a 0–5 volt signal. If you use the auxiliary output power source, slip the ferrite core over the positive conductor (see Figure 3, Case 1 and Figure 4A).



Warning: Take precautions when wiring the analog inputs. Reverse polarity may damage the main board or the sensor.

The auxiliary output on the mainboard can be used to power the transducer as seen in Case 1 of Figure 3 (250 mA maximum). When using the auxiliary output, be aware of the voltage drop in the 4–20 mA loop when wiring to the analog inputs. The auxiliary output supply voltage is software configurable for 0, 12, or 24 VDC.

If the MyDro is not powering an external device, you can set the output to OV to conserve power during battery operation.

Figure 3:
Analog Input Wiring

Case 1:

Power to Analog transducer supplied by Mission Auxiliary Out. (Selectable 12 or 24 VDC via Touch LCD).

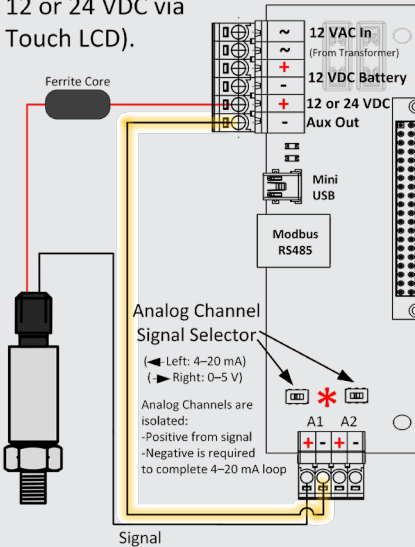

Case 2:

Power to Analog transducer supplied by external power source.

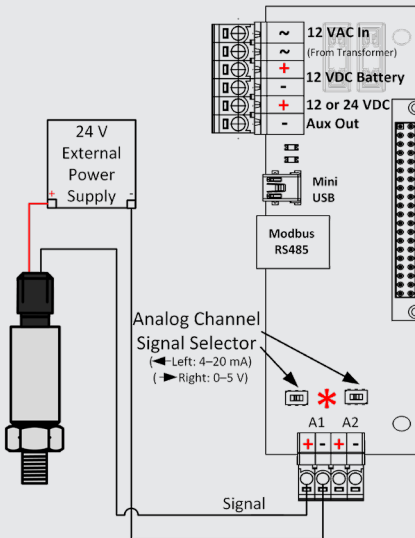
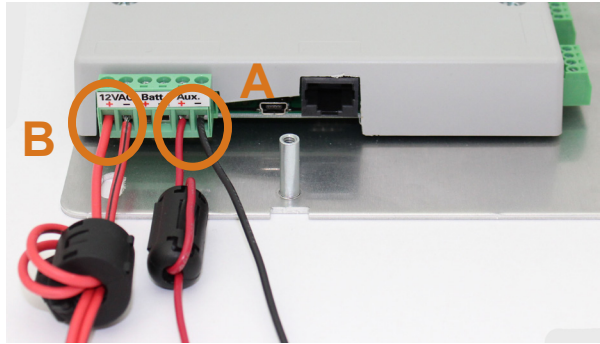

Figure 4:
Installing ferrite cores to (A) auxiliary output and (B) AC input



9. Wire the output relays. The output relays are single pole, double throw and rated up to 30 VDC maximum. They are used for remote control applications such as Tank and Well, and analog or digital interconnect. You can wire the relay normally open (default) or normally closed (refer to Appendix B).

If planning to use the Emergency Backup Pump Control feature, wire the output relays as shown in step 11.

One or two pumps can be connected to Relay 1 and Relay 2, depending on the installation. Pump 1 must be wired to Elk Relay or SSR connected to Relay 1. Pump 2 must be wired to the Elk Relay or SSR connected Relay 2. The corresponding number of AC switches must be wired to DI1 and DI2.



Warning: Relay behavior on communication failure is configurable under the Config. Menu/Relay Comm Fail Setup as Deenergize or No Change.



Warning: If power to output relays is supplied by Mission auxiliary power port it is software configurable as 12 or 24 VDC. Specify coil voltage of interposing relays appropriately. Best practices dictate that the on-board relays should not be used to switch 120Vac. Instead, use interposing relays to switch 120Vac.

If the MyDro is not supplying aux. power, the port can be turned off (0v) to conserve power when operating on battery power.



Note: Many items should be considered with remote control applications. Refer to the Best Practices for Remote Control document.

Wire the auxiliary output to common on the output relay. Wire the coil positive terminal on the interposing relay to normally open or normally closed on the output relay. Wire the negative coil terminal to Aux (-).

10. Install the 120 VAC transformer and wire AC power. Slip ferrite core over the two conductors going to the AC in connection (see Figure 4B). Mount the transformer in the control panel (not the Mission RTU).

It is very important to only provide 12–16 VAC to the Mission mainboard AC input. Hooking up the transformer backwards will apply 1200 VAC to the mainboard and cause permanent damage. Do not install transformer in the RTU. Install it in the control cabinet.



Warning: Connect AC power to the primary input (black wires). Connect the secondary output (red wires) to the mainboard input. The transformer steps the power down from 120 VAC to 12 VAC. Do not turn on station AC power at this time.

**Figure 5:
Transformer Wiring**

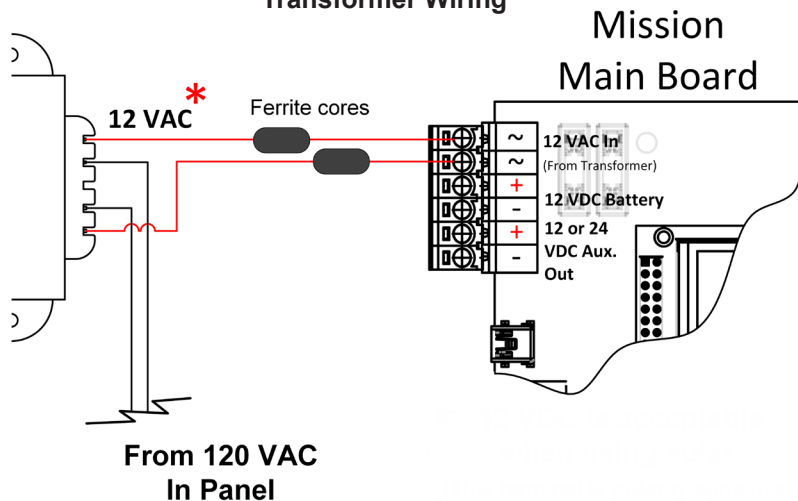

11. If using Emergency Backup Pump Control feature, continue wiring the RTU as illustrated in Figure 6.

Figure 6:
Emergency Backup Pump Control wiring

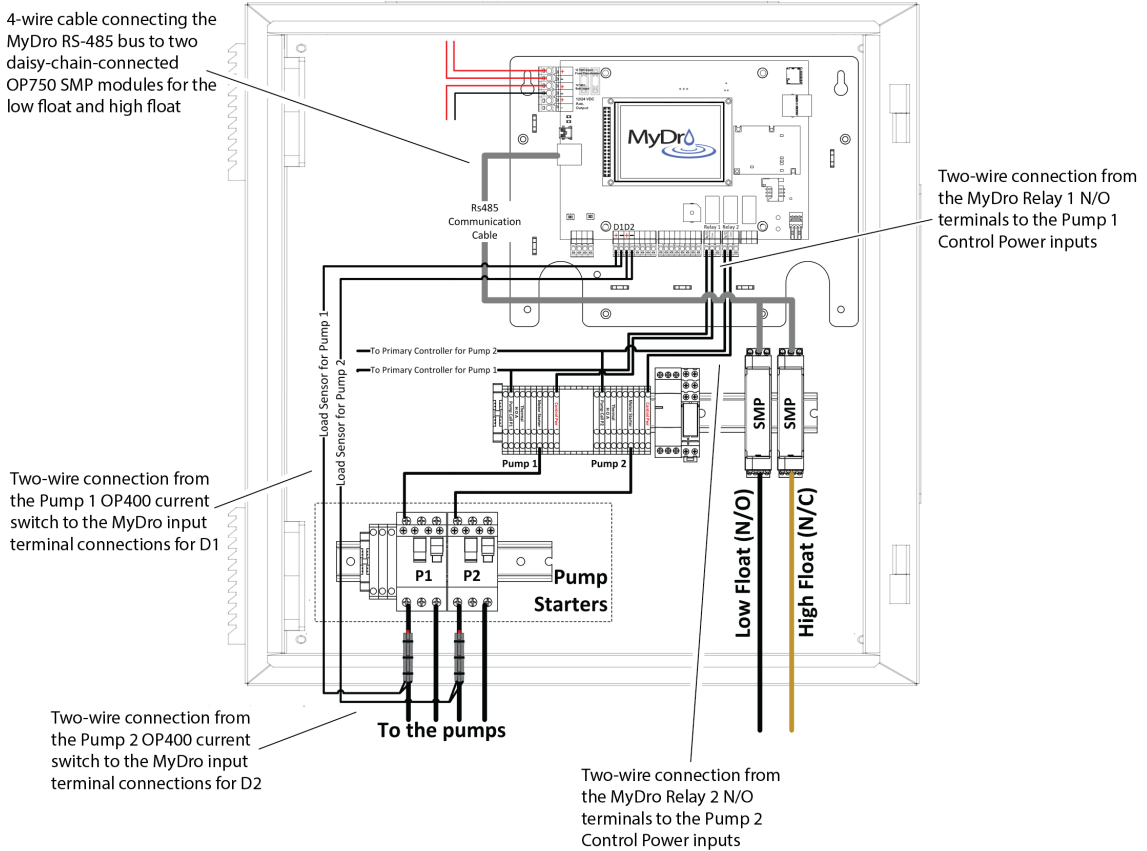

 **Note:** If your system will use direct connections to floats, they can be wired to any digital input from 3-8. Alternate current switches connected to D1 & D2 may also be used for detecting Pump 1 and Pump 2 current flow.

Chapter 5: RTU Startup

1. Power the Mission RTU with the 12 VDC battery only. Connect the black lead first, then the red lead (see Figure 6). The LCD will illuminate the start up screen. Once the radio sequence is complete, you will hear three beeps from the buzzer. This indicates the unit has connected to Mission servers. Allow the unit about two minutes to perform its power-up sequence and synchronization to the network. If the RTU does not connect after two attempts, contact Technical Support.

**Figure 7:
Battery Wiring**

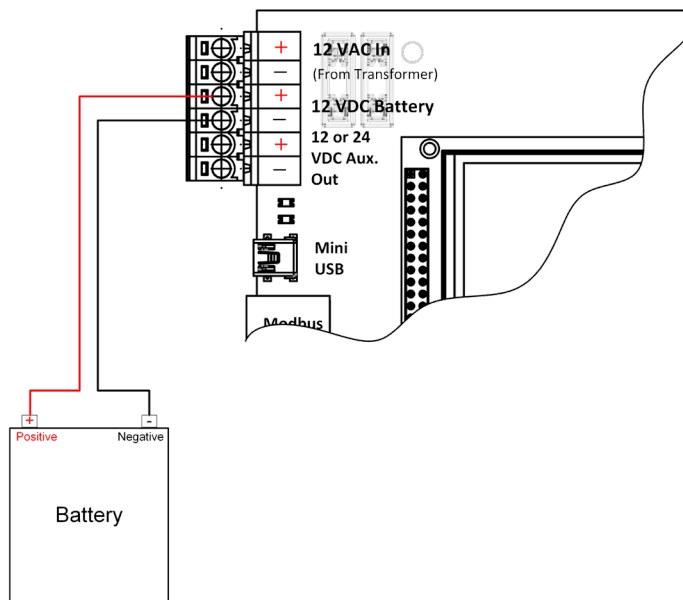

2. Check the wiring connections before powering the pump station. If the wiring is correct, power the pump station, and immediately focus on the mainboard. Check to ensure the Mission RTU is still operating. If a wiring mistake has been made, it will be evident. If there appears to be a mistake, immediately remove power. If everything is correct, proceed to testing the RTU.



Warning: There is a risk of explosion if the battery is replaced by an incorrect type. Dispose of used batteries in accordance with local regulations.

Chapter 6: Test the Installation

It is imperative that alarm points are tested and that alarm notifications are received so they can be acknowledged by the customer or end-user once the unit is put into production. This includes phone numbers, text messages, email addresses, fax numbers, and pager numbers.

Additionally, it is recommended that the customer or end-user test all alarm points every six months to ensure all electrical components and alarm parameters are still functioning as desired and that alarms are being received and acknowledged by recipients. Refer to the Spring Cleaning/Fall Fix-up document for testing procedures.

Complete the following tests prior to leaving the job site. Reference Figure 8: Test the Installation for these tests:

1. Confirm AC power. Use a voltmeter across the AC terminal to verify ~12–14 VAC is present.
2. Test the radio connection. Check the radio status on the LCD screen. It should read “connected.” If not, call Technical Support at (877) 993-1911 option 2.
3. Test the battery. Use the Config Key that shipped with the MyDro or another known Config Key to access Config mode. Use the Battery Test (6th screen) to test the battery.
4. Inspect the status on the LCD. Analog, digitals, etc.
5. Test the digital alarm inputs. Put each digital input into an alarm state. From the touch screen press digital and confirm inputs respond as expected. Mission Technical Support is available to confirm that data is being properly transmitted and received on your web portal. A smartphone can be used otherwise.
6. Test the pump runtime inputs. Turn on pump 1. Mission D1 should respond on the touch screen. If not, check the wiring and/or end-of-line resistors. Repeat step for pump 2 and 3, if used.
7. Test the high level alarm. Open the wet well. Pull the high-level float up and put it into alarm condition by tipping it. Ensure that the digital input four respond. If not, check the wiring and the high level float itself. If EBPC is enabled, pump down cycle starts.

Figure 8:
Test the Installation

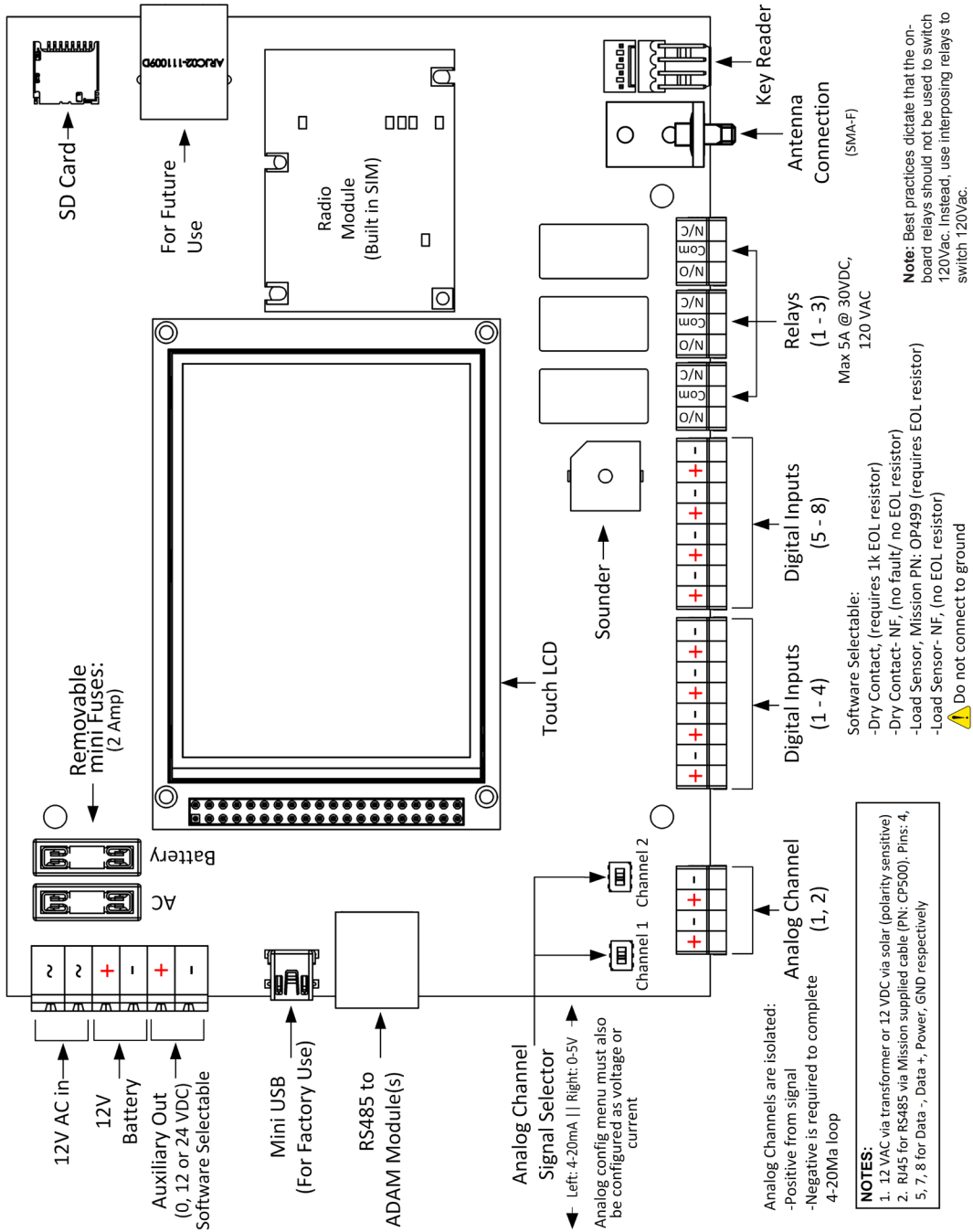

Verify alarm notifications are received from the tests. Log on to your web portal with the credentials specified on the Notification Setup Form. Go to the Alarms dashboard. You should see a list of alarm events with event time and the result.

Call Mission Technical Support after testing the installation to enable the device for alarm call-outs. A technician will verify proper operation of equipment.

You may find it helpful to download the 123SCADA mobile application, available for free download on the Apple App Store and Google Play Store.



Chapter 7: Electronic Key

The MyDro uses electronic keys, also referred to as config keys to log site visits, acknowledge alarms, and suspend alarms while service is being performed at the station. Each key can be configured in 123SCADA to include the following permissions and functions:



ACK: Using the key on the MyDro will acknowledge all pending alarms for the unit. Note that only alarms triggered while callouts are enabled will get acknowledged by this feature.

Time	Ack Type	Event	Ack Alarm
March 20 at 2:22:15 PM	✉	[149805872] ACK Enabled MyDro Key #7 acknowledged the Wet Well Level Normal at Nature Preserve Reservoir.	

Service: Using the key will put the MyDro into Service Mode. The display background turns yellow and notifications and callouts get disabled for any alarms that may be inadvertently triggered in the testing and troubleshooting process. Data is still transmitted from the MyDro. To exit Service Mode, tap the key to the reader once more and wait for the display background to return to black. Once this happens, an internal 1-minute timer begins before the unit truly exits service mode. This feature accounts for any other notification-sending actions that would trigger after the key press, such as door alarms on leaving the service site. Most keys enabled for service and config mode have the ACK function enabled as well, seen below

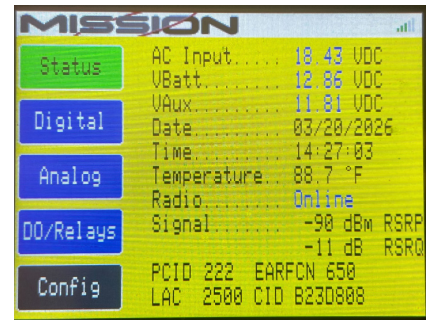

Time	Ack Type	Event	Ack Alarm
March 20 at 2:26:58 PM	✉	[149806050] MyDro Service Key #7 acknowledged the Wet Well Level Normal at Nature Preserve Reservoir.	
March 20 at 2:26:58 PM	✉	[149806047] MyDro Service Key #7 acknowledged the High Wet Well Alarm at Nature Preserve Reservoir.	
March 20 at 2:26:58 PM		MyDro Service Key #7 just accessed at Nature Preserve Reservoir.	

RTU Config: Using the key will put the MyDro into Config Mode. Config Mode includes all the features of Service Mode, while adding the ability to interact with and change configuration settings of the MyDro, provided the unit is online. When activated, the screen background turns yellow and the Config button in the bottom left will unlock, turning from gray to blue. From there, the user can cycle through various pages of configuration settings by repeatedly tapping the now-blue Config button. To exit Config Mode, tap the key to the reader once more and wait for the display background to return to black. Like Service Mode, the same one-minute countdown function will trigger on exiting Config Mode.

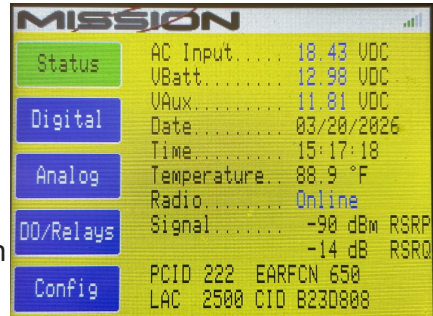

How to Use Your Electronic Key & Special Cases

- Press the metal portion of your key against the key reader firmly, ensuring complete, flat, circular contact. The MyDro will beep when a key press is detected.
- A MyDro has 3 main modes of operation; Normal, Service, and Config.
- A MyDro's mode can only be changed via a key interaction once every 20 seconds. Any key interaction within the 20-second countdown from a mode switch will reset the internal timer.
- Cold booting the unit will not reset the key reader function. The screen will return to normal, but the server will keep it in the state it was in before the cold boot.
- If a key that is not configured on the 123SCADA customer portal is used, the MyDro will beep, the screen will not turn yellow, and the mode will not change. The key interaction will be logged on 123SCADA.
- If the MyDro is offline and detects a key press, an Offline-Config Mode will activate, where only radio settings and firmware update options are available.

Mission offers additional configurable electronic keys (PN: CP450, package of 5), which are always available for order.

Chapter 8: Site Commissioning

Enable the RTU for alarm call-outs by calling Technical Support.

Setup Forms

Ensure setup forms have been submitted to setupforms@123mc.com. Verify proper labeling on your web portal and the wiring diagram on the Mission RTU. Users with Superadmin or Admin credentials have the ability to make changes to the web portal.

Documentation and Help Guides

It is recommended that you review the online manuals for detailed operation of your RTU and web portals. This can be found on your menu selection in the Download folder under Documents.

The Operators Guide that came with the RTU should be distributed to your operators as a how-to document to get operators started with the Mission system. It covers the basics of the system capabilities, monitoring and alarming, and helpful resources.

Training Resources

Mission hosts weekly webinars nearly every Wednesday at 2 P.M. Eastern. The revolving series covers the basics, advanced web portal options, and everything in between. Mission wants to help you get the most out of your system, so please join and feel free to ask questions.

Mission also offers short video tutorials and quarterly newsletters with timeless information. Registration and archives can be found on the website.

Your unit is now ready for use. Visit 123scada.com and log in with your credentials to view your web portal or go to 123mc.com to use the legacy web portal.

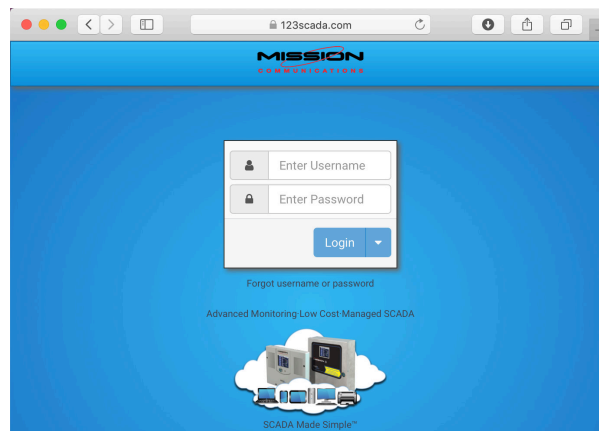

Appendix A: Terminology

Alarm Inputs

A digital or analog input that is configured to dispatch a notification when the alarm state or threshold is reached.

Analog Inputs

Two analog inputs on M150 and M850 series RTUs can be used to report pressure, level, chlorine pH, or any other dynamic readings by way of a 4–20 mA or 0–5 V transducer. High and low analog alarm thresholds as well as high and low restore set points can be set from the web portal. The M850 can be expanded to 6 analog inputs via expansion modules.

Digital Inputs

Eight inputs are available for sensing items like pump run, float status, or pump fail. They can be electrically configured (via LCD/Config/Digital Input) for dry inputs or the strap on current sensor where greater than ~5 Amps indicates run. They can be logically configured as alarm or accumulators for hourly pump run time and starts reporting. The M150 supports up to three pump run time accumulators, the M850 supports up to eight. Also see end-of-line resistor.

Digital Outputs

Three relay outputs can be remotely controlled to turn on pumps, wells, valves, or security lights. Multiple M850s can be linked so an event at one station causes a relay change at another. Mission's Tank and Well Control option and Intertie rely on this feature. Note: Best practices dictate that the on-board relays should not be used to switch 120Vac. Instead, use interposing relays to switch 120Vac. Consult Best Practices for Remote Control for more information (123mc.com/literature).

EBPC (Emergency Backup Pump Control)

This local, software-enabled feature allows the MyDro units to temporarily take over pump control for up to two pumps in the system, ensuring the lift station remains operational while waiting for a replacement pump controller.

Electronic Key Reader

The included key reader allows on-site personnel to log a site visit, acknowledge, and suspend alarms while service is performed at the station. Management can track the key entries for productivity and regulatory reporting purposes. The functionality of the key can be configured at the web portal.

End-of-Line Resistor

A resistor of known value (1000 ohm) that is used to terminate protective loops, and provide wire supervision. Wire the EOL in parallel to a switch instrument. The requirement for an end-of-line resistor is software configurable for fault (requires resistor) or no fault.

Long Term Evolution (LTE)

Generally known as 4G (see Radio Access Technology (RAT)) but by definition an evolutionary standard. 5G builds on the LTE standard with the addition of millimeter wave and ultra low latency technologies. The small radio waves are appropriate for dense urban areas but not good for long distance propagation.

M150 vs. M850

Generally, the M850 is more appropriate where analog sensors are present, at master lift stations, and for remote control applications. Both RTUs provide real-time alarms. The M150 accumulates pump starts each hour whereas the M850 reports real-time pump state changes. The M850 reports analog values every two minutes or sooner (>5% change) for trending purposes. The M150 supports up to three pump runtime inputs whereas the M850 supports up to eight.

Metal Oxide Varistor (MOV)

The included MOVs are used to protect circuits against high transient voltage spikes, often caused when relay coils de-energize. They are rated for 150 volts. Voltage above 150 volts will be dissipated. The MOVs are non-conductive during normal operation. Consult your electrician before installing the MOVs.

Power and Backup Power

The M150 and M850 RTUs operate on 12 VAC via the supplied transformer. The 120 to 12 VAC transformer mounts outside the RTU to minimize the chances of induced voltages. A five Amp-hour battery with a charging circuit powers the RTU for 18–50 hours (M850 and M150) during a power failure. AC power fail alarm will be dispatched. A low battery alert will be dispatched in the morning if the battery voltage fell below 11.5 volts anytime the previous day.

Pulse Inputs Options

Pulse inputs can be used to report data such as flow, water meter, or rainfall totals. If no rainfall data is monitored at the site, Mission's web site presents data from the closest National Weather Service reporting station. Four pulse inputs are available with the Safe Module Plus.

Radio Access Technology (RAT)

As cellular networks evolve, radios must be updated to the current RAT. See Long Term Evolution (LTE).

Runtime Inputs

A digital input that is configured to calculate runtime minutes and pump starts each hour. Alarm notifications are generally not enabled for runtime inputs.

SIM (Subscriber Identity Module)

This card carries an identification number that contains the billing credentials for certain cellular radio. Removal of card will disable operation.

Appendix B: Output Relay Diagram

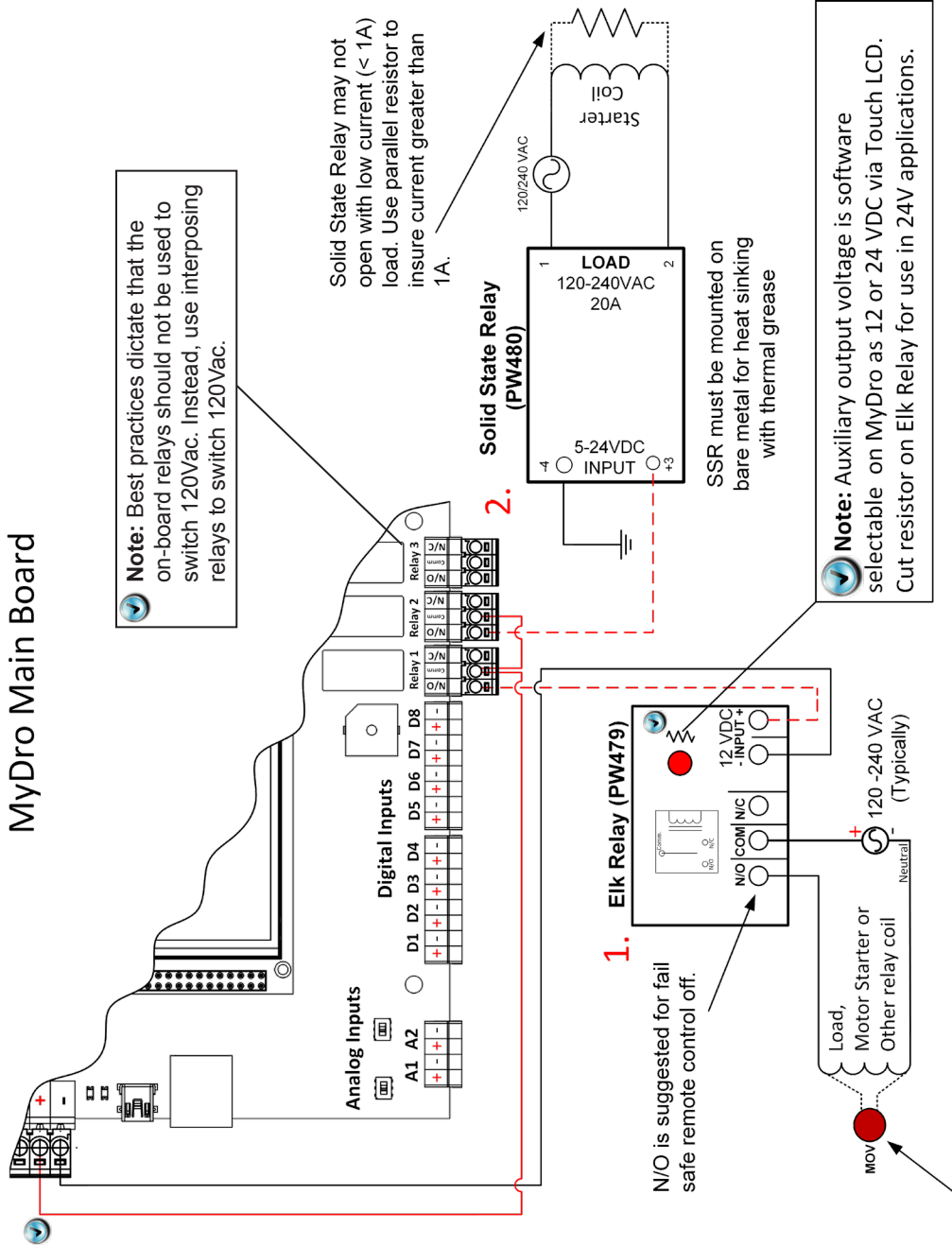

To suppress spikes during turn-Off of inductive loads, use a properly sized MOV (12, 24, 120 VAC, etc. rated) across relay coil. If this load is DC-driven, use a 1N4004 (max rating 240V) diode across the load, cathode tied to the positive terminal.



Web
123mc.com

Technical Support
(877) 993-1911 option 2
techsupport@123mc.com,
setupforms@123mc.com

Sales
sales@123mc.com
(877) 993-1911 option 4

M1M8IM-2603