

## Sewer Overflow Alarm and Tracking System

Avoid spills with surcharge and high-level conditions notifications

### Track Manhole Surcharges and Overflows

Floats tipped by surcharges and high levels signal Mission servers to initiate notifications via phone call, email, text message, fax, and pager. Secure web portal offers CSO and SSO reports that include the date, time, and duration of CSO and SSO events with corresponding rainfall amounts.

### Expanded Data Collection

The device supports two digital inputs from either electrical or optical floats. (Two electro-mechanical floats included.) A built-in photodetector can be used to generate a vandal alarm notification.

### Long Operating Life

The highly efficient electronic circuitry is powered by a high ampacity field replaceable lantern battery. Under normal CSO, SSO monitoring applications the system can operate over 5 years on one battery.

### Simple to Install

The device installs in the chimney of the manhole using a versatile mounting bracket that accommodates the float cables and can be adapted to sloping walls. The in-ground antenna is installed adjacent to the manhole. Antenna and float terminations are home runs eliminating the exposure of the harsh environment to terminations. Installation can be completed with common tools and does not require manhole cover modifications or entry into the manhole.

### Waterproof, Self-Contained, and Safe in Sewers

The downward facing bell shaped IP 68 rated enclosure features double seals for the ultimate environmental protection. The intrinsically safe device is injected molded from carbon fiber ABS plastic and third party certified for use in hazardous sewer environments.

### Easy to Access Information

The top facing e-paper display shows the last information reported and can be viewed without removal of the device from the bracket. The device can be configured from your web portal.

### Reliable Communications

The Manhole Monitor Plus features LTE CAT 1 cellular radios for reliable data transmissions. Data payloads are fully acknowledged—unlike SMS messages. There are no radios to program, cellular contracts to set up, or software programs to buy. Dual SIM (active/active) configurations are available for added high availability benefits.

### Managed Service – The Complete Package

The service includes all communications, data storage, alarm call-outs, reports, and technical support. Alarm conditions are recorded and reported in real-time while device health status is transmitted daily. All data and reports can be accessed from any web-enabled device, and the data is archived forever. No engineering or programming is required.



**New Enclosure  
New Features**

- Double-sealed bell shaped enclosure for ultimate durability
- High capacity lantern battery for longer operating life and convenience
- Advanced cellular radio
- Top facing E-Paper displays shows last information without wakeup requirement for convenience and power efficiency
- Supports optical or electro-mechanical floats

### Future features:

- Accelerometer for tilt based notifications
- Bluetooth for connection troubleshooting
- Modbus connection for flow monitoring

# Dimensions

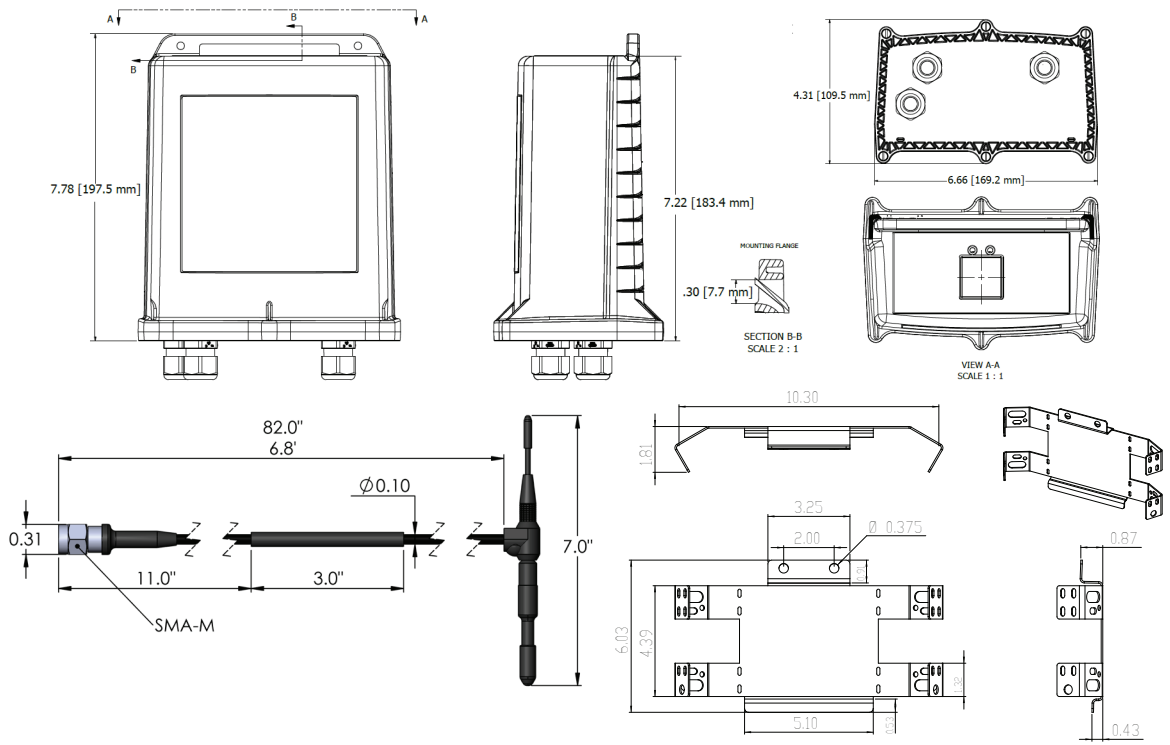

# Specifications

## Enclosure:

- Corrosion, static, and impact resistant carbon fiber ABS plastic enclosure
- Double sealed lid for Ingress protection
- Enclosure hangs on Included bracket or can be attached to wall with screws

## Power:

- Field replaceable RayOVac 808 6.0VDC 36.6 Whr lantern battery
- 5-year nominal lifetime when sensing optical float tip.

## Inputs and Sensors:

- (2) Electromechanical floats included; Optical floats can be purchased if desired
- (2) Dry contact inputs are available which can be connected to electromechanical float, hatch door sensors or other passive digital switches
- Configurable debounce delay for nuisance alarm prevention
- Photo detector for notification on change of light typical of sewer lid removal
- Accelerometer available to report enclosure angle or tamper (future feature)
- Built-in Inputs Include board temp, battery voltage and cellular signal strength

## Alarm Notifications and Heart Beat:

- Alarm notifications on state change of all Inputs configurable via web portal
- Built-in Inputs transmitted daily and function as a heart beat

## Radios:

- North America (AT&T, T-Mobile, Verizon + Canada)
- Bands:
  - B12: AT&T, T-Mobile
  - B14 AT&T/ FirstNet
  - B4 AT&T, Verizon, T-Mobile
  - B2 AT&T, Verizon, T-Mobile
  - B5 AT&T, Verizon, T-Mobile
  - B13 Verizon
  - B66 AT&T, T-Mobile, Verizon,
  - B71 T-Mobile (600MHz)

- Embedded and removable SIM

## Antenna:

- In-ground, omnidirectional (PN RF8003)
- SMA male (cable) to SMA female (enclosure) connection

## Included Installation Hardware:

- Stainless steel, multifaceted mounting bracket
- TapCon stainless steel masonry bolts, (4) 1" x 3/4" and (2) 2" x 1/4"
- (1) 3/16" diameter masonry drill bit
- (2) Carabiners
- Tie wraps
- Asphalt sealant
- Drying agent

## Physical:

- Enclosure: L: 6.68", W: 4.32", H: 7.88" (H: 9.88" including connectors on enclosure)
- Enclosure: 3 lbs. (with battery installed)
- CAD files available for enclosure and mounting bracket

## Configuration, Display and

### Diagnostics:

- Locally configurable via 123SCADA SmartPhone app over Blue Tooth Low Energy (BLE) (future feature)
- Remotely configurable via web portal and cellular network
- Top facing E-Paper display shows most recent transmission even when device is dormant as well as diagnostic information

## Configurable Parameters:

- Radio options
- Input debounce time
- Language selection (English, Spanish and French)
- Transmission frequency
- Modbus node address (where applicable)

## Environment:

- Operating: -10 to 50 °C
- Display: 0 to 50 °C
- INTRINSICALLY SAFE WARNING – Replace RayOVac 808 (6.0VDC 36.6Whr) battery only in a location known to be non-hazardous.
- SÉCURITÉ INTRINSÈQUE AVERTISSEMENT – Afin de prévenir toute déflagration, changer les piles [RayOVac 808 (6.0VDC 36.6Whr)] uniquement dans des endroits sûrs et sans danger.
- Use damp cloth to clean and remove static charge.
- Utiliser un chiffon humide pour nettoyer et éliminer la charge statique
- EU RoHS compliant

## Modbus (future release):

- 2 wire (D+ D-) support for flow meters and other Modbus Instruments
- Modbus Register mapping done via web portal
- 9600 baud standard, can be set to faster rates

## Warranty:

- Enclosure and electronics: 5 years
- Battery: 5 years based on 400 transmissions per year\*
- Floats: 1 year

## Optional Accessories:

- Optical Float (PN IT8410 - 10', IT8420 - 20', IT8430 - 30')
- Above-ground antenna (PN RF8006)
- Replacement in-ground antenna (PN RF8002)
- Pole mount antenna kit (PN RF8005)
- Replacement RayOVac battery Model number (PN PW445) also available locally
- 10' Mercury-free Float, water resistant, safety colored cable, normally-closed, mechanically-activated, 90 degree open (PN IT8401)
- 20' Mercury-free Float, water resistant, safety colored cable, normally-closed, mechanically-activated, 90 degree open (PN IT8402)
- 30' Mercury-free Float water resistant, safety colored cable, normally-closed, mechanically-activated, 90 degree open (PN IT8403)
- Masonry drill bit, 3/8" x 24" (PN T8000)

Certified Class I, II, III, Division 1 Groups D-G, T1 and Intrinsically Safe.



Class I Zone 0, Ex ia IIA Ta Ga.



(877) 993-1911 • sales@123mc.com • 123mc.com

\*Additional service plans available for higher data transmission rates.

MMP-2105